

Summer 2010

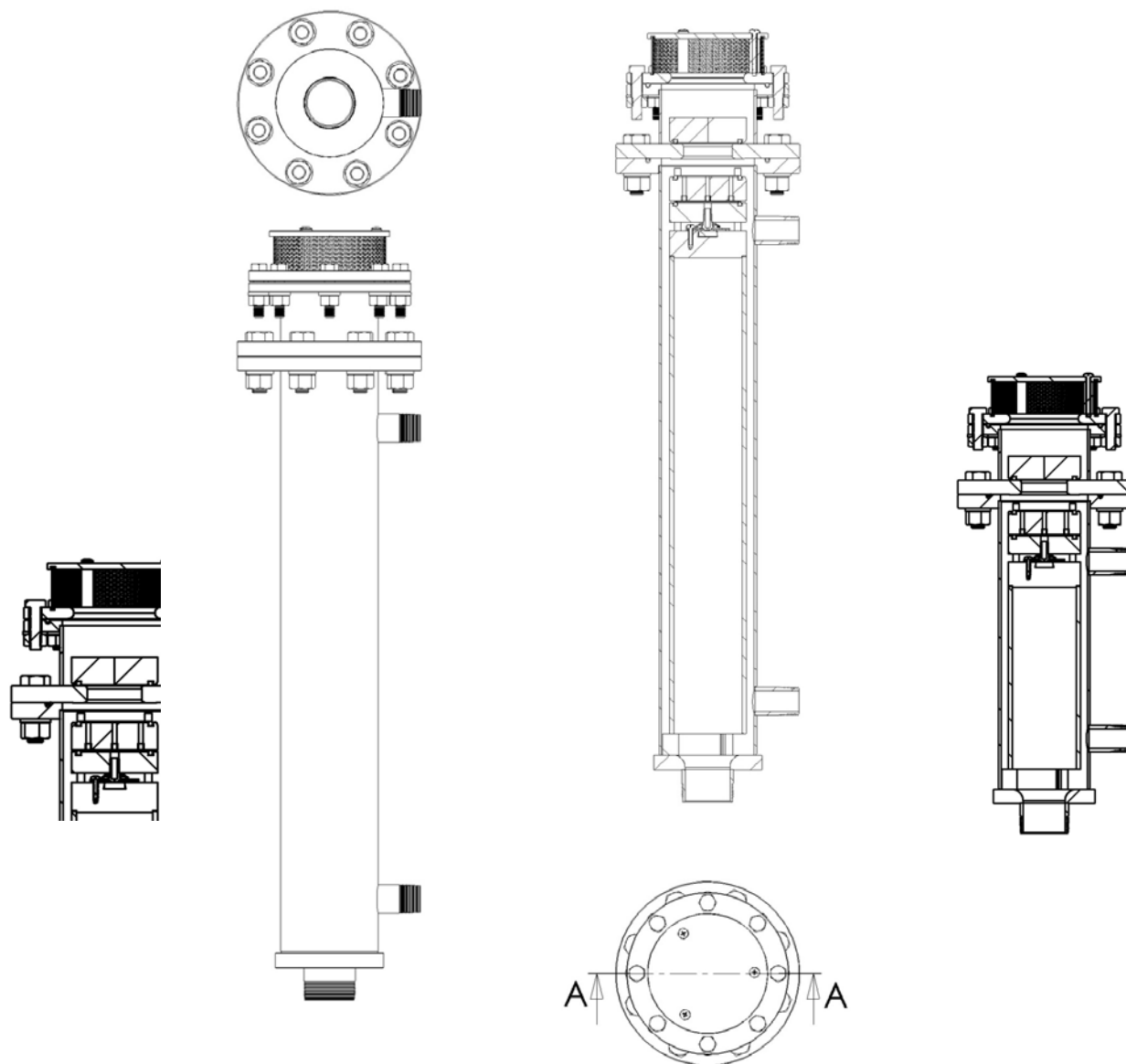

Vent-Tech
Combination Sewage Air Relief Valves
SWG Series



Supplementary Information

Vent-Tech Sewage Air Relief Valve
Supplementary Information
Valve Sizing

Sizing of Combination Air Venting Valves

Valve sizing and valve positioning can be a complex undertaking. For large, complex flow dynamics, engineers will often recommended the use of computer modeling to understand the surge and pressure wave dynamics that occur during pump start-up, shut-down, valve closure and system failure modes. Generally, however, venting valves are specified at the apex of an undulating pipeline and at approximately every third of a mile. Ideally, the placement of these valves would coincide where the pipeline changes in gradient or direction.

Besides venting entrained gases under normal operational modes, these valves perform two main duties which are governed by different events and physics: (1) controlling vacuum induced buckling or collapse of the pipeline by limiting suction to -5 psi; and (2) exhausting trapped gasses during pipeline filling. The suction event is governed by the maximum flow of the pipeline under either controlled operations, or as is more typical, by uncontrolled shut-down or rupture. Velocities induced during flow down a long steep hill can easily exceed the normal pumping rates.

The exhausting of gases during filling operations is more simply driven by the capacity of the pumps used during filling, and in these cases it is recommended that the valves exhaust velocity be limited to 60 meters per second. The valve at an apex needs to be sized to handle the max pump capacity, and once this is set, the valve sizes on the uphill gradient will likely be determined by its suction duty, since all the ‘filling air’ can adequately escape through the apex valve. And, because drainage rates may greatly exceed filling rates, even the apex valve size may be determined by its ability to limit suction.

For simpler installations, the table below offers guidance in Vent-Tech’s standard valve selection.

Vent-Tech Valve Size (inches)	Line filling Rate Max GPM	Based on -5psi Vacuum Rate Max GPM (Standard Valves)
1	1,270	1,570
2	4,950	6,280
3	10,910	14,350
4	18,790	21,840
6	42,650	49,150
8	73,860	87,380
10	116,420	136,540
12	166,980	196,610

The SWG-B Valve Series are sized on vacuum rates only. The Vent-Tech size for these valves can be determined by reducing the maximum GPM (shown above) by seven percent (7%).

Vent-Tech Sewage Air Relief Valve
Supplementary Information
Valve Installation

Selection and installation of the Vent-Tech Combination Air Relief Valves should be made with careful review by the system engineers. Based upon the years of experience and expertise of International Valve, critical elements of a successful air relief valve installation are shown below in a typical fiberglass “drop in” pre-assembled valve vault.

KEY COMPONENTS OF THE RECOMMENDED LAYOUT

(SIZES WILL VARY)

N.T.S.

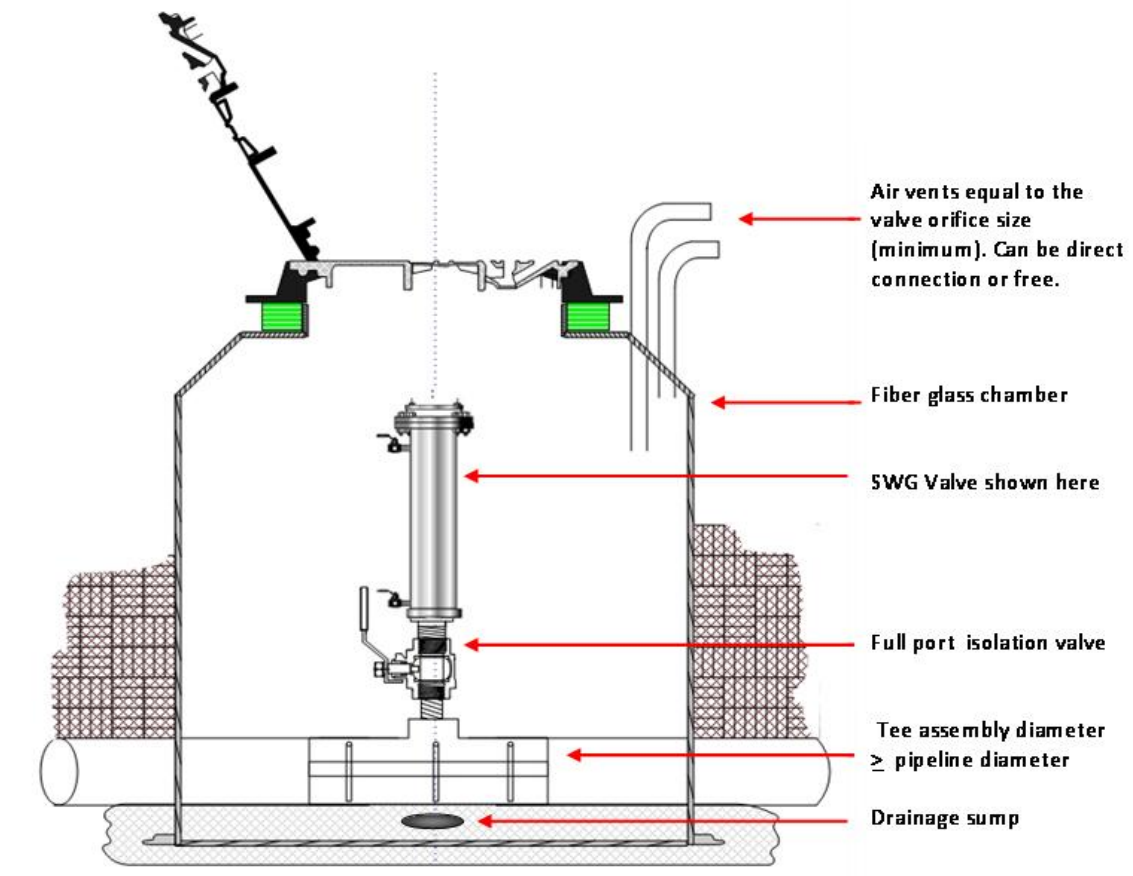

For more information on pre-assembled “drop in” fiberglass valve chambers with Vent-Tech Valves, see www.internationalvalve.com

Vent – Tech
 Valve End Connection Details
VALVE INLETS

INLET CONNECTIONS

Screwed Stud

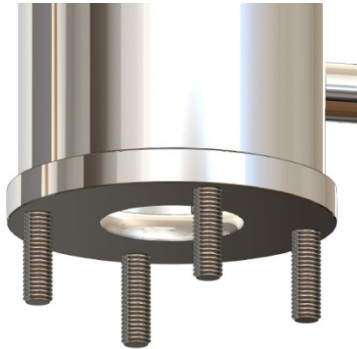

- Bar 10 and 16 (3", 4", 6", 8")
- Bar 25 (2", 3", 4", 6", 8")

Male NPT Threaded

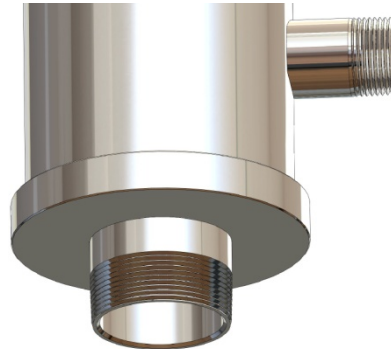

- Bar 10 and 16 (2" only)
- Not available in Bar 25 Valves

DN	Valve Size	Inlet Connction 10 Bar Valves	Inlet Connction 16 Bar Valves	Inlet Connction 25 Bar Valves
050	2-Inch	2" Male NPT Threaded Connection	2" Male NPT Threaded Connection on Flange	ANSI B16.5 Class 300 Flanged 8 screwed studs
080	3-Inch	ANSI B16.5 Class 150 Flanged 4 screwed studs	ANSI B16.5 Class 150 Flanged 4 screwed studs	ANSI B16.5 Class 300 Flanged 8 screwed studs
100	4-Inch	ANSI B16.5 Class 150 Flanged 8 screwed studs	ANSI B16.5 Class 150 Flanged 8 screwed studs	ANSI B16.5 Class 300 Flanged 8 screwed studs
150	6-Inch	ANSI B16.5 Class 150 Flanged 8 screwed studs	ANSI B16.5 Class 150 T Flanged 8 screwed studs	ANSI B16.5 Class 300 Flanged 12 screwed studs
200	8-Inch	ANSI B16.5 Class 150 Flanged 8 screwed studs	ANSI B16.5 Class 150 Flanged 8 screwed studs	ANSI B16.5 Class 300 Flanged 12 screwed studs

Bar	DN	Valve Size	A Inches	B Inches	C Inches
10 & 16	050	2-Inch	NA	2	NA
25	050	2-Inch	6.5	2	5.0
10 & 16	080	3-Inch	7.5	3	6.0
25	080	3-Inch	8.25	3	6.62
10 & 16	100	4-Inch	9.0	4	7.50
25	100	4-Inch	10.0	4	7.88
10 & 16	150	6-Inch	11.0	6	9.50
25	150	6-Inch	12.5	6	10.62
10 & 16	200	8-Inch	13.5	8	11.75
25	200	8-Inch	15.0	8	13.00

FLANGE DIMENSIONS

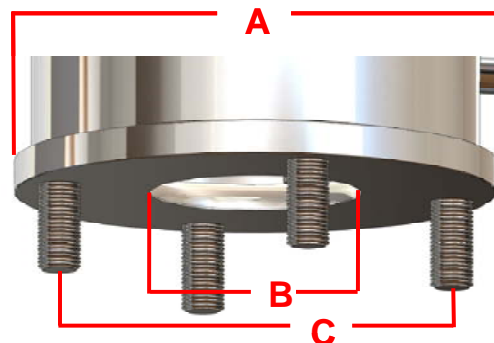

Vent – Tech
 Valve End Connection Details
VALVE OUTLETS, PORT and ISOLATION VALVES

2 - 3 - 4 - Inch Valves

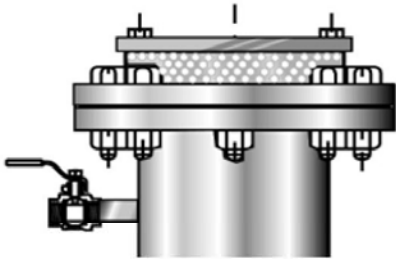

STANDARD EXIT ORIFICES ARE PROTECTED WITH PERFORATED ROUND HOLE STAINLESS SHEETING. FEMALE NPT THREAD CONNECTION

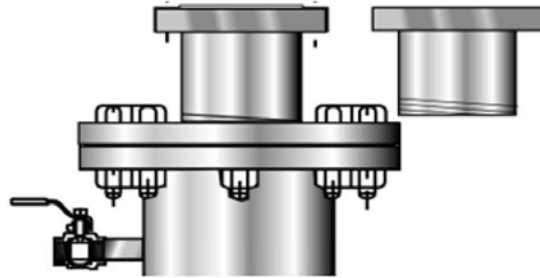

OPTIONAL ACCESSORY: REMOVE STANDARD SCREENING AND ADD RETROFIT SWIVEL FLANGED OUTLET. SCREWED CONNECTION.

6 - 8 - Inch Valves

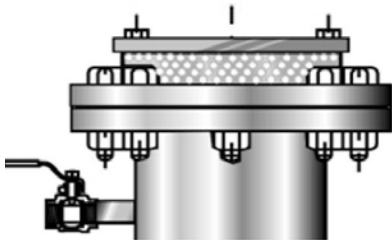

STANDARD EXIT ORIFICES ARE PROTECTED WITH PERFORATED ROUND HOLE STAINLESS SHEETING.

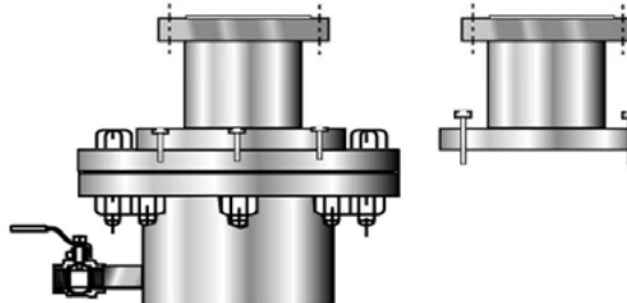

OPTIONAL ACCESSORY: REMOVE STANDARD SCREENING AND ADD RETROFIT SWIVEL FLANGED OUTLET. ALLAN HEAD CONNECTION.

Port Valves

ALL VALVES ARE SUPPLIED WITH TWO SIDE PORT VALVES.

TWO 1 INCH PORT VALVES FOR THE 2-3-4 INCH

ONE 1 INCH & ONE 1 ½ INCH PORT VALVE FOR THE 6-8 INCH

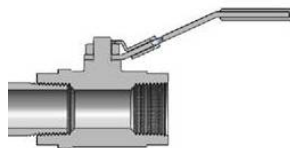

Isolation Valves

ISOLATION VALVES CAN BE ORDERED AS ACCESSORY.

FULL PORT 0 312SS IS STANDARD.

SEE SPECS FOR DETAILS

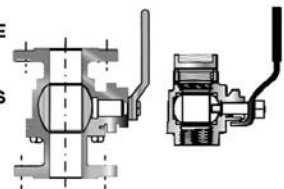

Vent-Tech
Supplementary Information
Additional Details **Nozzle Float**

Nozzle Float Details*

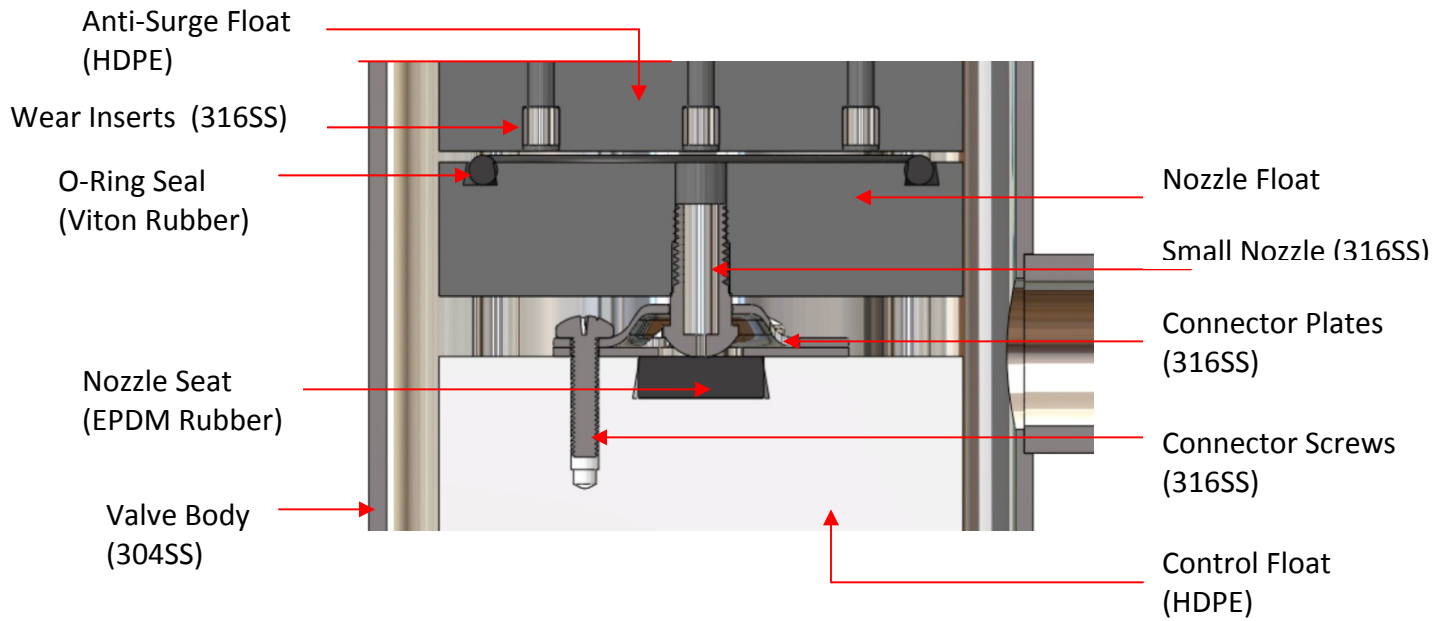

*International Valve – Patent Pending

Vent-Tech
Supplementary Information
Additional Specifications

Additional Purchase and Operating Specifications

For all materials, please refer to Material Specifications and their Details.

The Air Relief Sewage Valve shall be constructed using a hollow cylindrical stainless steel body. For standard pressures, the Valve is straight and for high pressure Valves, the body is designed with contours. Each Valve contains an open ended Control Float, a Nozzle Float and a multi-orifice Surge Float. The Floats are made of HDPE or UHMW.

The multi-orifice Surge Float has anti-wear inserts on the orifice. This Float shall perform routinely to control transient pressure rise or shock created by a valve closure whenever the valve pressure is 50% or less than the valve's pressure rating.

The exit orifice shall be of equal size or greater than the intake orifice, and sizing shall conform to the rated size of the Valve. The NB (Nominal Bore) of the Valve shall be equal to its Valve sizing.

Closure of the large Valve orifice shall be by seating the flat HDPE Anti-Surge Float, containing a peripheral, dovetailed Viton O-Ring against the top flange.

The lower hollow Control Float shall have a rubber seat, which allows the small exit nozzle of the Nozzle Float to sit when the Valve is closed. Discharge of pressurized air or gas shall be accomplished by the seating and unseating of the small nozzle on the rubber seat. The nozzle face shall be constructed so that repeated seating does not damage the rubber seat.

The Valve shall not show any signs of leakage, float distortion or material change when operated under its normal operating pressure rating, nor up to 150% its rated pressure.

At pump start-up, prior to fluid entering the Valve, the air/gas shall vent to the atmosphere through its large orifice. With an increase in fluid velocity, which may cause a transient pressure rise, the multi-orifice Surge Float shall close the large orifice and discharge the exhaust through the Surge Float orifices. This shall be an automatic function, to maintain transient pressure rises below a 50% increase in the Valve's rated pressure.

Valves shall remain water tight and pressurized within the Valve's performance pressure rating and up to 50% higher for surge conditions.

Valves shall remain water tight and pressurized and discharge exhaust gases through the small nozzle of the Nozzle Float at the designed pressure rating. In the absence of air, the nozzle shall not leak.

By fully opening the large orifice of the Valve, the Surge Float shall respond directly to any negative pressure which may be created by sudden pump stoppage or column separation. The air intake shall be unimpeded and flow freely to negate any negative pipeline pressure.

International Valve reserves the right to change the product specifications without notice.

Vent-Tech
 Supplementary Information
Ordering System

Nomenclature

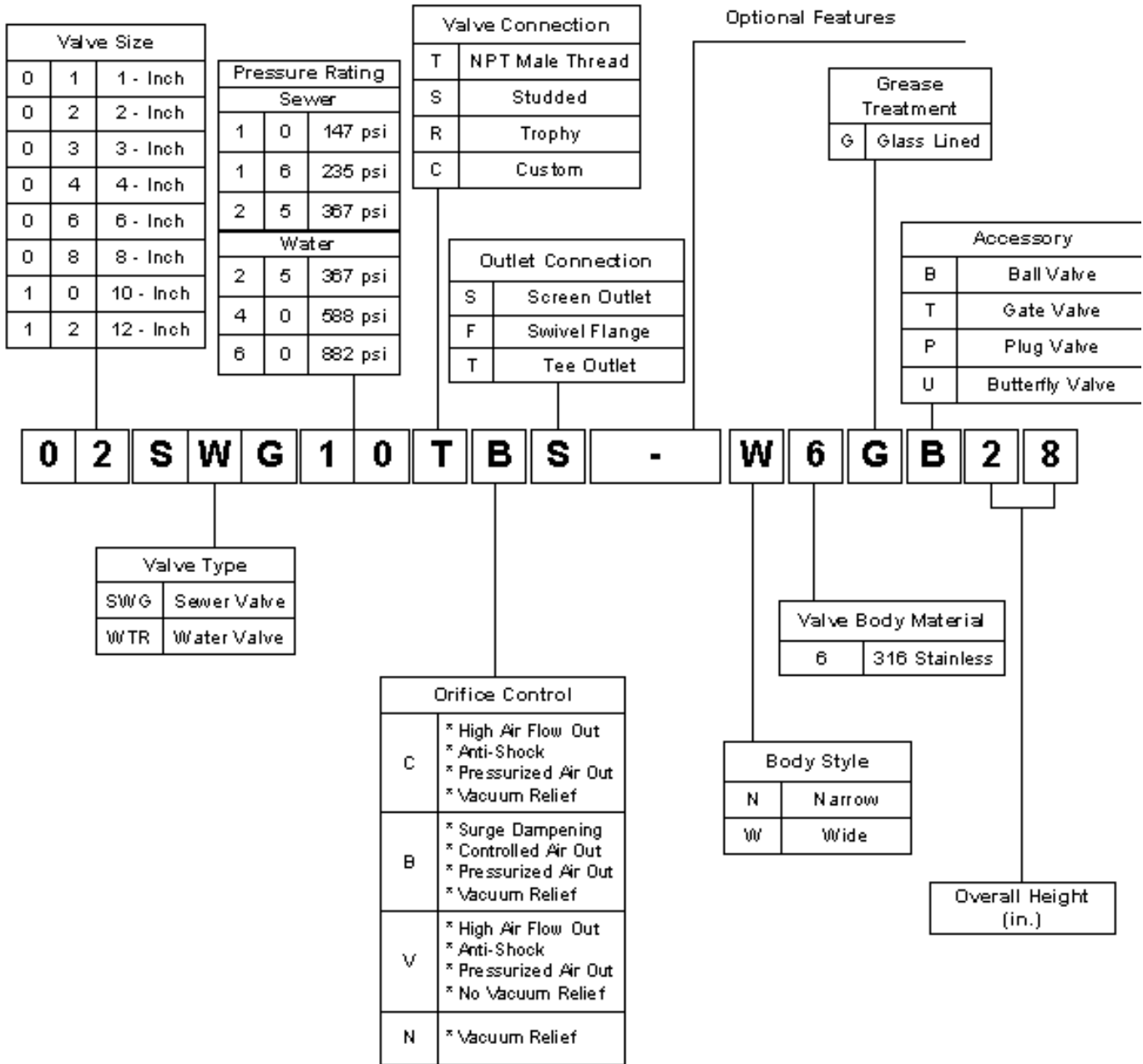

Vent-Tech
Supplementary Information
Warranty

International Valve Marketing ('Company') guarantees that the goods supplied will conform to specifications and to any requirements specifically accepted by the Company in writing in regard to each order. Except as stated in the preceding sentence, the Company gives no warranty, express or implied, of the material workmanship or fitness of goods for any particular purpose whether such purpose is known to the Company or not.

In accordance with the specifications or requirements included herein, should defects under proper use appear in the goods within a period of 12 (twelve) calendar months after the goods have been delivered, which is caused solely by faulty design, materials, or workmanship, the Company shall, if requested to do so within a reasonable time, but not later than 18 (eighteen) calendar months from date of delivery, repair such goods or the defective parts thereof, free of charge by supplying other goods or replacement parts at the initial place of delivery which do comply with specifications or requirements aforesaid and/or which are free of the defects identified in the complaint.

The above factory warranty is further extended by International Valve Marketing to specifically extend the aforesaid Valve Warranty to 12 (twelve) calendar months to include an additional 108 (one hundred eight) calendar months for a total warranty timeframe of ten (ten) years, or 120 (one hundred twenty months) from date of delivery. Additionally, included in this extended warranty, is the express condition that all or any replacement parts shall be delivered free of charge for these calendar months.

It is a condition of this guarantee that: International Valve Marketing be given reasonable time and opportunity to comply with terms of the guarantee/warranty.